

LC 218-SK2

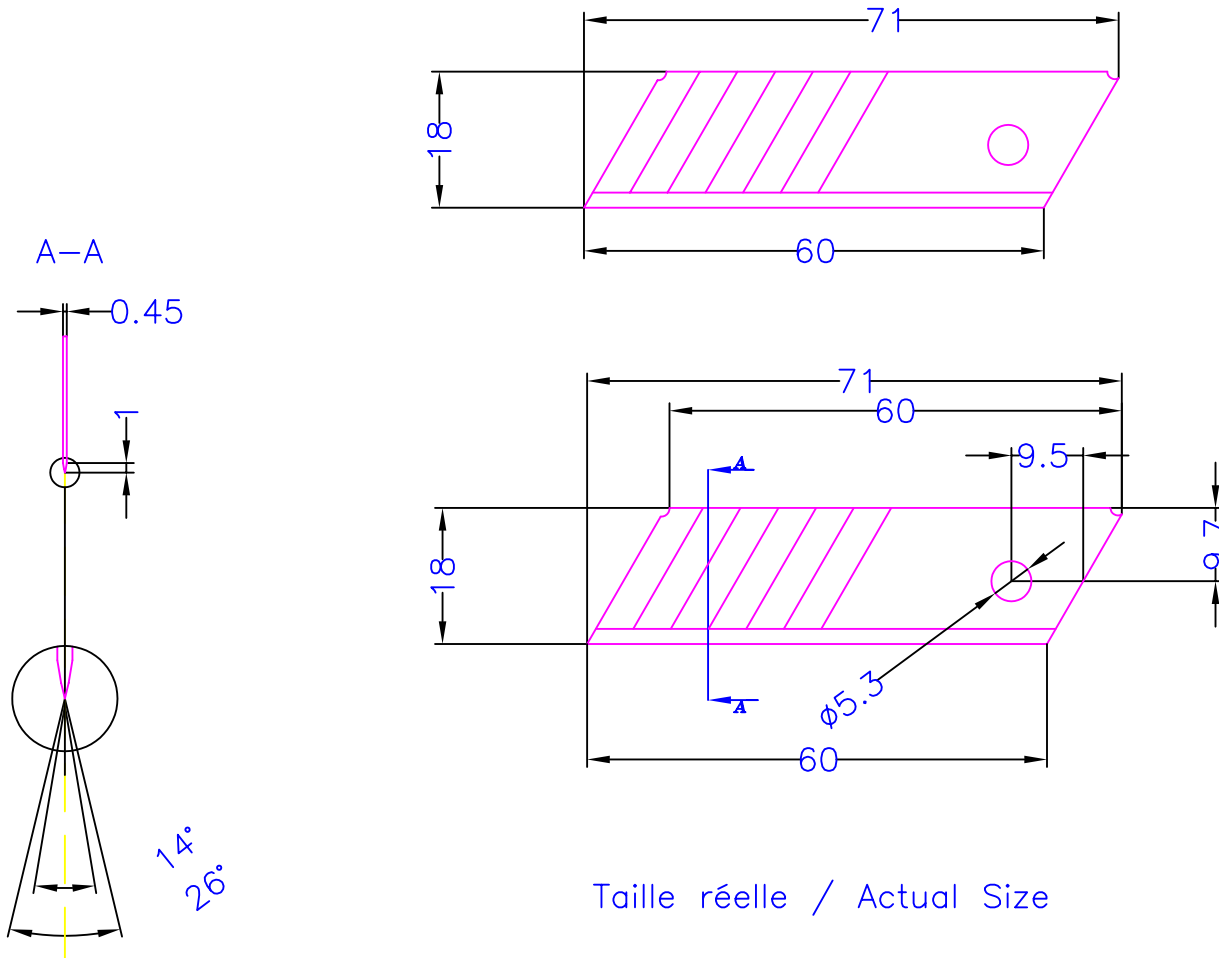

Taille réelle / Actual Size

Section echelle 2/1

Dureté\Hardness\Härte\Durezza:	64 HRC
Angle d'aiguisage\Angle of grinding Schleifwinkel\Angulo de afilado	Angle N° 1 : 14° Angle N° 2 : 26°
Matériau\Material Materialien\Materiales	Acier SK 2 1.25%Carbone\ steel SK 2 1.25% Carbon\ stahl SK 2 1.25%Kohlenstoff\Acero SK 2 1.25%Carbono

Indice/Issue Index/Índice			Texte descriptif de la Modification / Amendement Aenderungstext / Texto de la modificación		Date / Date Datum/Fecha	Nom / Name Name/Appellido	<p>Les côtes sans tolérances seront tolérances en accord avec : Dimensions without individual tolerances according to : Zul.Abweichungen fuer masse ohne toleranzangabe nach : Las dimensionnessin tolerancia individual conforme a :</p> <p>DIN ISO 2768 Milieu/Médium Mittel/Medio</p> <p>N° de plan/Drawind Nbr Zeichungs-Nr/Plano N°</p>
PLANCHE: 1/1	Date / Date Datum/Fecha	Nom / Name Name/Appellido	<p>Accordant Marketing Limited Unit 4 Cooperage Green Royal Clarence Yard Weevil Lane Gosport Hampshire P012 1AX Tel : 023 92 501552 / Fax : 023 92 503951</p>				
Desiné / Drawn Gezeichnet/Delineado	01/06/04	TECH					
Vérifié / Checked Geprüft/Verificado	01/06/04	TECH					
Imprimé / Ploted Geplottet/Trazado	01/06/04	TECH					
Echelle / Scale Mabstab/Escala	1/1	LC 218-SK2 Cutter Blade 18 mm					