

# LC 009-SK2

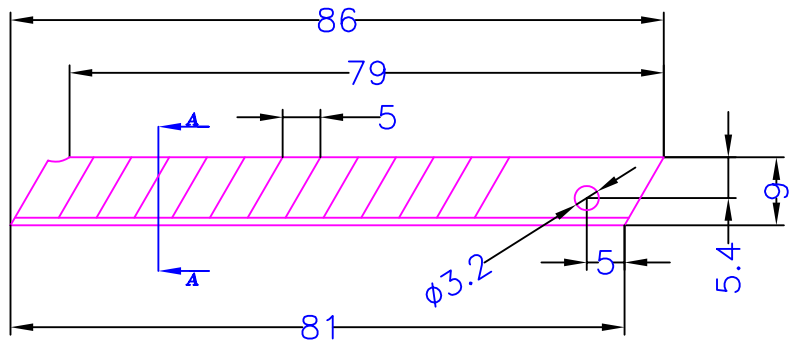
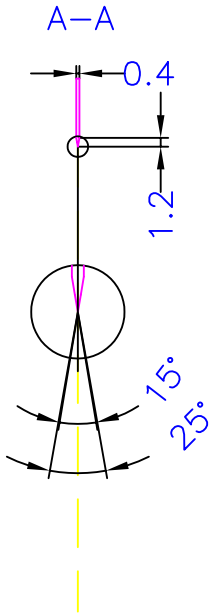
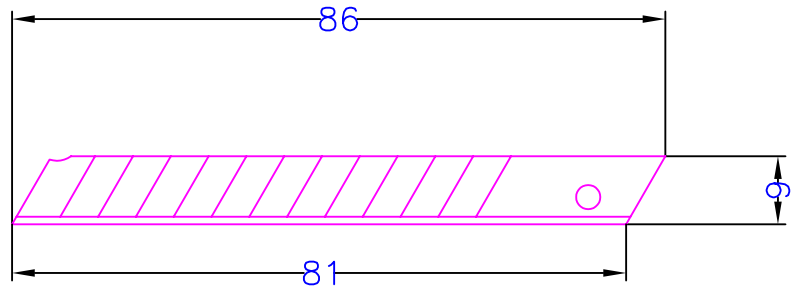

Taille réelle / Actual Size

Section echelle 2/1

<b>Durete\Hardness\Härte\Durezza:</b>	64 HRC
<b>Angle d'aiguisage\Angle of grinding Schleifwinkel\Angulo de afilado</b>	Angle N° 1 : 15° Angle N° 2 : 25°
<b>Materiau\Material Materialien\Materiales</b>	Acier 1.25%Carbone\ steel 1.25% Carbon\ stahl 1.25%Kohlenstoff\Acero 1.25%Carbono

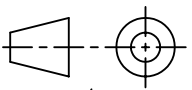
Indice/Issue Index/Índice			Texte descriptif de la Modification / Amendement Aenderungstext / Texto de la modificación		Date / Date Datum/Fecha	Nom / Name Name/Appellido	Les côtes sans tolérances seront tolérances en accord avec : Dimensions without individual tolerances according to : Zul.Abweichungen fuer masse ohne toleranzangabe nach : Las dimensionnessin tolerancia individual conforme a :  <b>DIN ISO 2768</b> Milieu/Médium Mittel/Medio   N° de plan/Drawind Nbr Zeichungs-Nr/Plano N°
PLANCHE: 1/1	Date / Date Datum/Fecha	Nom / Name Name/Appellido	<b>Accordant Marketing Limited</b> Unit 4 Cooperage Green Royal Clarence Yard Weevil Lane Gosport Hampshire P012 1AX Tel : 023 92 501552 / Fax : 023 92 503951				
Desiné / Drawn Gezeichnet/Delineado	01/06/04	TECH					
Vérifié / Checked Geprüft/Verificado	01/06/04	TECH					
Imprimé / Ploted Geplottet/Trazado	01/06/04	TECH					
Echelle / Scale Mabstab/Escala	1/1	LC 009-SK2		Cutter Blade 9 mm			